



KNIFE GATE VALVES

A LUG SERIES

GEARS

- It is recommendable for DN greater than 600.
- **B = max. width** of the valve (without actuator).
B = max. height of the valve (without actuator).
- Options:
 - Chainwheel.
 - Limiting switches.
 - Extensions: stand, pipe, plates,...
 - Non-rising stem.
- Actuator comprising:
 - Stem.
 - Yoke.
 - Cone-shaped gear box.
 - Handwheel.
- Standard reduction ratio = 4 to 1.
- Available: DN 50 to DN 2000, other DN on request.

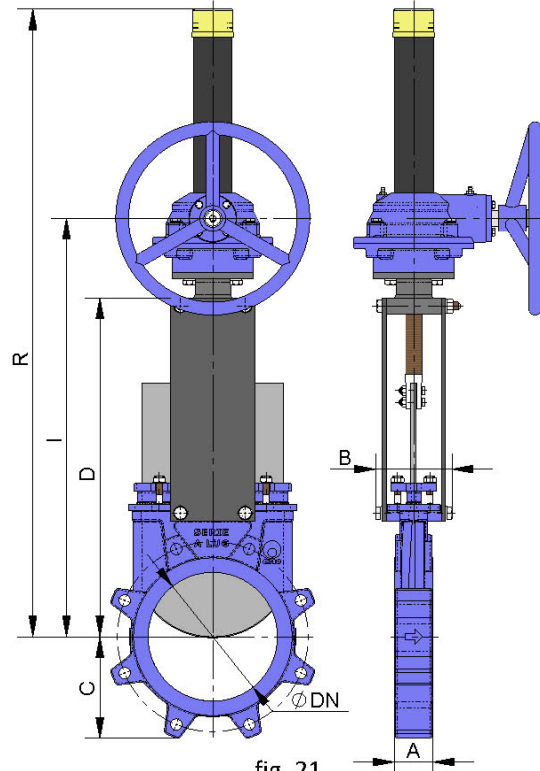

fig. 21

DN	ΔP (Kg/cm ²)	DRAW (Nw)	TORQUE (Nm)	A	B	C	D	I	R
50	10	830	1,91	60	91	61	241	365	537
65	10	1400	3,22	60	91	68	268	392	564
80	10	2120	4,9	64	91	91	294	418	590
100	10	3310	7,61	64	91	104	334	458	630
125	10	5180	11,9	70	101	118	367	491	663
150	10	5970	14	76	101	130	419	543	715
200	8	9300	27	89	118	158	525	649	943
250	6	10400	30	114	118	196	616	740	1033
300	6	15000	43	114	118	230	704	828	1121
350	5	16380	63	127	290	247	767	891	1305
400	5	21430	83	140	290	290	865	989	1403
450	3	20044	79	152	290	304	989	1113	1677
500	3	25230	98	152	290	340	1101	1225	1788
600	3	36510	142	178	290	398	1307	1428	1995
700	2	32945	180	178	320	453	1506	1658	2401
800	2	43493	238	178	320	503	1720	1872	2715
900	2	55024	301	178	320	583	1953	2105	3043
1000	2	68580	375	178	320	613	2137	2290	3351
1200	2	99026	643	203	340	728	2616	2802	4042
1400	2	136885	889	150	390	837	3250	3415	4852
1500	2	158591	1191	170	426	890	3517	3675	5217
1600	2	180653	1519	170	426	957	3775	3945	5575
1800	2	230715	1940	190	440	1057	4242	4415	6242
2000	2	289155	2761	210	480	1162	4540	4720	6740

table 8

C.M.O.

Amategui Aldea 142, 20400 Txarama-Tolosa (SPAIN)

TEC-A LUG.EN05

Tel. Nacional: 902.40.80.50 Fax: 902.40.80.51 / Tel. Internacional: 34.943.67.33.99 Fax: 34.943.67.24.40

cmo@cmo.es <http://www.cmo.es>

page. 15